



KENWORTH
THE WORLD'S BEST



T470

PUSHING FOUR FEET OF SNOW OR HAULING 10 YARDS OF SAND, THIS IS YOUR HEAVY-DUTY CHOICE IN A MEDIUM-DUTY TRUCK

The versatile new Kenworth T470 merges just the right mix of brain and brawn to forge a whole new class at the heavy end of what is usually termed “medium duty.” It’s the ideal workhorse solution for snowplow, and other heavy front-axle vocational and municipal applications that require full parent rail extensions.

Available in GVW ratings from 33,000 lbs to 68,000 lbs, the T470 features modern styling, superior ergonomics, and a fuel efficient powertrain – all, in a robust chassis design meant to deliver a lot more value over the long haul.

With full parent rail extensions providing maximum resistance to bending moment (RBM) from one end of the rail to the other, the T470 supplies a solid and durable mounting platform for hydraulic pumps, winches, front stabilizers and snow plows.

Front axles are rated from 12,000 to 22,000 lbs., single rear axles from 21,000 to 30,000 lbs., and tandem rear axles from 40,000 to 46,000 lbs. allowing for GVW rating



KENWORTH.
The World's Best.

from 33,000 lbs to 68,000 lbs. Powerplant choices include the powerful yet low cost of ownership PACCAR PX-8 engine rated to 350 hp and 1,000 lb-ft of torque or the Cummins ISL engine with 380 hp and 1,300 lb-ft of torque.

Featuring a set-back front axle, a tight turning radius and an optional automatic transmission, the T470 is agile, comfortable and easy to drive for new and experienced drivers alike – even in congested urban situations.

Standard equipment includes best-in-class forward lighting with Halogen projector headlamps, a 3-piece aluminum or box steel bumper, multiplexed dash incorporating Kenworth's Driver Information Center and a productive, doghouse-free premium interior. Optionally, Kenworth offers its spacious Extended Day Cab with an additional six inches of length and five inches of cab height, high intensity discharge (HID) lighting, cab air suspension, factory-installed power take-off (PTO) and one lift axle.



Clean frame rails and an exhaust-free back of cab clear the way for quick and efficient installation of a wide range of bodies and chassis-mounted equipment. A weather-tight pigtail simplifies final wiring assembly. These attributes provide cost effective body installations.



The T470 incorporates the same highly reliable and ergonomic multiplexed dash installed in Kenworth's Class 8 product line. Body specific controls and gauge installation is facilitated by the reserved dash panel which is conveniently located and easy for drivers to reach.

SAVING MONEY ON MAINTENANCE STARTS RIGHT HERE



On a Kenworth T470, things are quicker to get to, less strenuous to take apart and faster to put back together which means less downtime and lower repair bills. Even daily inspections have been simplified with all fluid level checks – coolant, oil, power steering and windshield washer reservoir – located in one strategic location.

At the heart of the T470 is a fully optimized and integrated drivetrain featuring the quality and proven reliability of the PACCAR PX engine. Expect longer service intervals, increased uptime, lower operating costs and higher resale value.

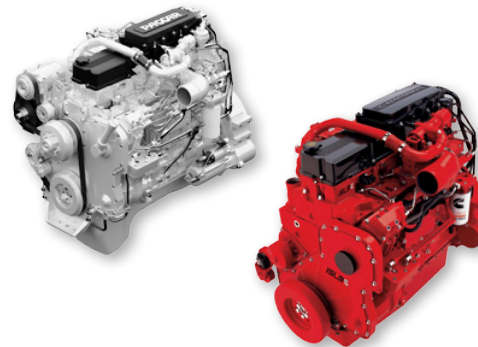

To meet your specific job requirement, you can choose between the rugged PACCAR PX-8 engine rated at 350 HP and 1,000 lb-ft of torque or the Cummins ISL at 380 HP and 1,300 lb-ft of torque.



Kenworth's stylish grille is made of stamped stainless steel – not plastic or pot metal – for enhanced strength and long lasting good looks. It's mounted to the radiator allowing the hood to swing clear of front mounted equipment. The bumper is constructed of three pieces for fast, economical installation of winches, PTOs and other front-end equipment.



OF COURSE YOU HAVE CHOICES. THIS IS YOUR KENWORTH.

Your T470 is available with plenty of job-specific and appearance options. Here are just a few of them.



The fully-trimmed standard Summit interior shown with optional Kenworth Air Cushion Plus high back driver seat and Kenworth Toolbox Plus low back passenger seat.



Optional center console with two power ports, cup holder and convenient storage makes the perfect in-cab workstation.



Easy-to-reach and operate dash control panel for Allison automatic transmissions. Also incorporates a handy cup holder.



DEF tanks in three sizes complement your choice of fuel tank size and provide fill interval options appropriate for your application. Fuel tanks in 22" and 24.5" range in size from 56 to 150 gallon, to offer clear back of cab configurations.



Cab corner windows greatly enhance visibility in tight places.



To add a distinctive look to your T470, Kenworth offers a wide variety of chrome and polished options. Polished aluminum wheels, fuel tanks and DEF tank covers are just few.



An advanced forward lighting system provides up to 30% more down-road coverage than conventional sealed beam designs.



Heated and electronically-controlled aerodynamic mirrors minimize road spray, keeping visibility at a maximum.

HEAVY-DUTY SUPPORT WHENEVER – AND WHEREVER – YOU NEED IT

The reliability and moneymaking potential of your business relies on the dependability of your support system – another great reason to invest in a Kenworth.

The minute you take delivery of your Kenworth, you gain 24/7 access to one of the most extensive and reliable parts and service organizations in the trucking industry. People who know your truck inside out and can show you how to lower operating expenses, maximize uptime, optimize truck performance and profit from your investment. Comprehensive preventive maintenance programs, expedited servicing, complimentary roadside assistance and cost management service cards are among the valuable programs available through Kenworth PremierCare®.



Perhaps you'd prefer to focus your attention and resources on your core business, save interest expense and improve cash flow. PacLease offers a number of truck rental and leasing programs that can be tailored to fit your operating requirements precisely. www.paclease.com

Start with a lender who understands your business. PACCAR Financial has served owner-operators and fleets for nearly 50 years, matching individual requirements with customized financing packages at attractive and competitive rates. Financing has never been this easy. www.paccarfinancial.com



T470 SPECIFICATIONS - GVW 33,000 TO 68,000 LBS.

Engine

- PACCAR PX-8 Engine, 260 HP, 660 lb-ft of Torque
- PACCAR PX-8 ratings up to 350 HP, up to 1,000 lb-ft of Torque
- Cummins ISL Engine ratings up to 380 HP, up to 1,300 lb-ft of Torque
- Cummins ISL-G Natural Gas Power, 320 HP
- Fire Truck Ratings Available
- CARB Emission Reduction Feature Available

Starting & Charging

- Electrical System with Centralized Power Distribution Incorporating Plug-In Style Relays & Circuit Protection for Serviceability
- 160 Amp Bosch Alternator
- 130 and 270 Amp Alternator Options
- PACCAR 12 Volt Starter
- Two PACCAR Dual Purpose Batteries
- 3 Dual purpose, 2 Starting and 2 or 3 Deep Cycle Optima Batteries

Exhaust Options

- DPF & SCR RH Under with Vertical Tailpipe RH Side of Cab
- DPF & SCR RH Under with Vertical Tailpipe RH Back of Cab
- Vertical Independent SCR/DPF RH/LH Back of Cab
- Vertical Independent Muffler RH Back of Cab (ISL-G Only)

Transmission

- Eaton Fuller FS6406A 6-Speed
- Clutch - Eaton Fuller
- 6, 9, 10, 11 and 13 Speed Eaton Fuller Transmissions
- Allison Automatic 5 and 6 Speed HS, RDS and EVS
- Front Engine PTO Adaptor

Frame / Axle / Suspension / Brakes

- Frame - 10 5/8" x 3 1/2" x 5 1/16" Steel - 120,000 psi - Heat Treated
- Frame - 10 3/4" X 3 1/2" x 3/8", 10 11/16" X 3 1/2" x 1/2"
- 50.5" Bumper Setting
- 73" Extended Bumper Setting
- Full Frame Insert for 10 5/8" and 10 3/4"
- Partial Inserts for 10 5/8" and 10 3/4"
- Front Axles - Dana Spicer, 12,000 lb.
- Front Axles - Dana Spicer, 13,200 to 22,000 lb.
- Front Axles - Meritor, 12,000 to 20,000 lb.
- Front Springs - Taperleaf w/Shocks, 12,000 lb.
- Front Springs - Taperleaf w/Shocks, 13,200 to 22,000 lb.
- Single Rear Axle - Dana Spicer, 21,000 lb.
- Single Rear Axles - Dana Spicer, 22,000, 23,000, 26,000 & 30,000 lb.
- Dual Rear Axles - 40,000 to 46,000 lb.
- Rear Suspension - Reyco 21,000 lb.
- Rear Suspension - 23,000 to 46,000 lb. - Kenworth, Reyco, Hendrickson, Neway & Chalmers
- Single Pusher Axle
- Single Tag Axle
- ABS System - Bendix

Wheels / Tires

- Wheels - Steel 22.5"
- Aluminum 22.5" & 24.5"
- Alcoa Dura-Bright Aluminum Wheel Finish
- Tires - Bridgestone
- Up to 445 Series

Fuel Tanks

- Aluminum - 56 Gallon, 22" Round Aluminum
- Round Aluminum 22" and 24.5" from 75 to 150 gallons

Battery Boxes / Bumpers

- Aluminum Battery Box with Aluminum Diamond Plate Cover
- In Cab Battery Box Under Passenger Seat
- Bumper - Tapered Steel Channel - Painted
- Bumper - Tapered Aluminum Channel - Natural Finish
- Bumper - 3-Piece Offset Aluminum or Steel

Cab / Hood / Interior

- Cab - Aluminum and Composite
- Extended Day Cab
- 38 Inch AeroCab FlatTop Sleeper
- Hood - Sloped with Fixed Grille
- Interior - Smooth Gray Vinyl with Black Dash Trim
- Power Door Locks
- Passenger-side Electric Window
- Kenworth Air Cushion Plus High Back Driver Seat
- Kenworth Intermediate and High Back, Air and Toolbox Rider Seats
- 2-Person Bench Seat
- Sears Driver and Rider Seats
- Rear Cab Corner Windows
- Kenworth Multifunction Driver Information Center
- 9 Gauge Instrumentation
- 7.5" x 5" Body Builder Instrument Panel
- 4 Additional Gauge Locations
- Workstation Between Seats
- Halogen Projector Headlamps

Special Equipment & Options

- Aerodynamic Heated Mirrors
- Heavy Duty Crossmembers
- Factory Installed PTO's
- Quiet Cab Package
- Switch & Wiring for Customer Installed Fog Lights & Floodlights
- Left & Right Cab Mounted Halogen Spotlights
- Single and Dual Beacon Lights
- Factory Installed BOC Floodlights
- Daytime Running Lights
- Multi-function Engine Connector for Body Builder Interface
- Bodybuilder Harness
- Adjustable Telescoping Tilt Steering Column
- Remote Keyless Entry
- Bumper Delete
- Rear Engine Power Take Off (REPTO)
- Front Engine Power Take Off (FEPTO)
- NFPA Compliance Options

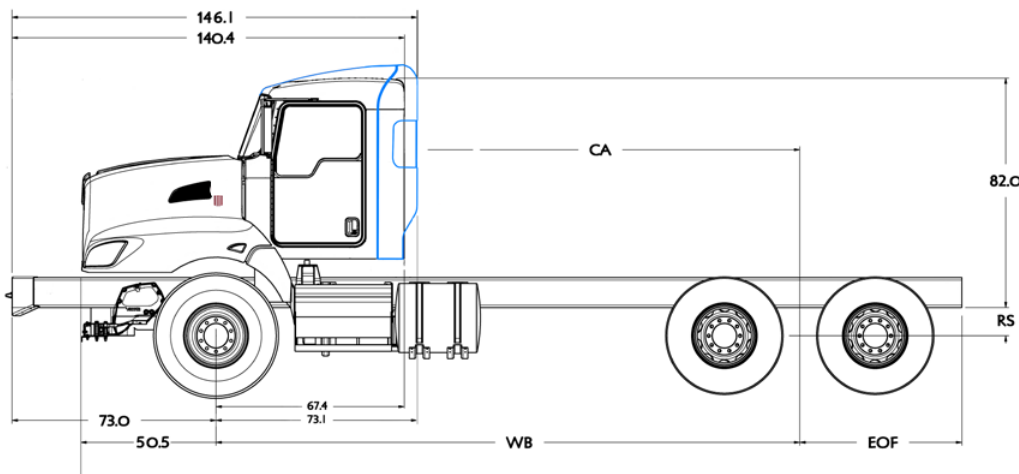

Note: Equipment and specifications shown in this brochure are subject to change without notice.

Consult with your Kenworth dealer at time of ordering for standard and optional equipment.



A PACCAR COMPANY

KENWORTH TRUCK COMPANY

P.O. Box 1000

Kirkland, Washington 98083-1000

(425) 828-5000

CANADIAN KENWORTH COMPANY

6711 Mississauga Road N.

Mississauga, Ontario L5N 4J8

(905) 858-7000

